

INSTALLATION, OPERATION AND MAINTENANCE INSTRUCTIONS FOR NEW YORK 18W SERIES



IMPORTANT SAFEGUARDS:

When using electrical equipment, basic safety precautions should always be followed including the following:

READ AND FOLLOW ALL SAFETY INSTRUCTIONS

1. Do not use outdoors.
2. Do not let power supply cords touch hot surfaces.
3. Do not mount near gas or electric heaters.
4. Equipment should be mounted in locations and at heights where it will not be subject to tampering by unauthorized personnel.
5. The use of accessory equipment not recommended by the manufacturer may cause an unsafe condition.
6. Do not use this equipment for other than its intended use.
7. Before wiring to power supply, turn off electricity at fuse or circuit breaker.
8. Installation and servicing should be performed by qualified personnel.

SAVE THESE INSTRUCTIONS

INSTALLATION

1. Remove front cover.
2. Mount the equipment securely in place on wall. Two additional key hole mounting holes are located at the top of the unit housing in addition to the J-Box mounting holes. These 2 additional mounting slot holes must be used when the unit is mounting to the wall. Additional chain support may be required by local codes. Chain hook holes are provided at each end of the enclosure.
3. Extend 24 hour AC supply of rated voltage to the equipment, which is furnished with a dual voltage 120/277 VAC field selectable input (see Illustration). Connect unit to utility power using an approved connector. For 120V supply connect the line wire to the black lead, for 277V supply, connect the line wire to the orange lead. Connect Neutral wire to the white lead. Connect Ground wire in accordance with local codes. A green ground lead is provided. **DO NOT** energize circuit at this time.
4. Install and connect battery. Refer to the illustration. Connect the red (+) lead from the PC board assembly to the battery (+) terminal. Connect the blue (-) lead from the PC board assembly to the battery (-) terminal. **CAUTION:** Observe polarity. Failure to connect the battery properly will result in equipment failure and an unsafe condition. **NOTE:** The emergency lights **WILL NOT** light at this time.
5. Energize the AC supply. The CHARGE indicator will illuminate.
6. Replace the cover.
7. Adjust and focus the lighting heads as required.

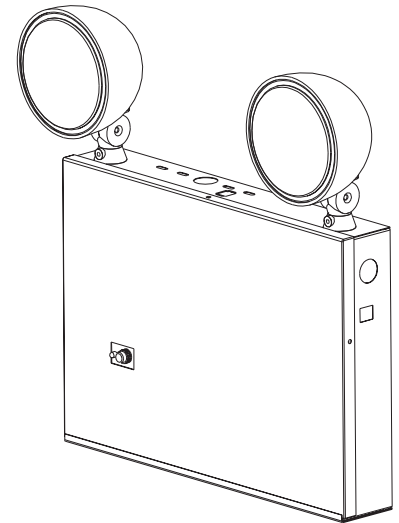

OPERATION

1. To test the equipment, depress the TEST switch. The CHARGE indicator will go off and the emergency lights will illuminate.
2. Release the TEST switch. The emergency lights will go out and the CHARGE indicator will illuminate.
3. The automatic charger will return and maintain the battery in a fully charged state.

NOTE: Allow the battery to charge for a minimum of 24 hours after installation or after a power failure before conducting a 90 minute test (see Testing). **CAUTION:** This equipment is furnished with a sophisticated solid state transfer switch which will automatically disconnect the emergency lights from the battery if the battery has been discharged to the end of its useful output.

INSTALLATION, OPERATION AND MAINTENANCE INSTRUCTIONS FOR NEW YORK 18W SERIES



IMPORTANT SAFEGUARDS:

When using electrical equipment, basic safety precautions should always be followed including the following:

MAINTENANCE:

Caution: Always turn off AC power to the equipment before servicing. Servicing should be performed only by a qualified service technician. Use only MANUFACTURER supplied or APPROVED replacement parts.

- BATTERY:** The battery supplied in this equipment requires no maintenance. However, it should be tested periodically (see Testing) and replaced when it no longer operates the connected fixtures for the duration of a 30 second or 90 minute test. The battery supplied in this equipment has a life expectancy of 5-7 years when used in a normal ambient temperature of 72° F.
- OTHER:** Clean lenses and replace lamps as required.

TESTING:

Paragraph 31-1.1.7 of nfpa 101-1985, Life safety Code requires that all emergency lighting equipment be functionally tested every 30 days for a minimum of 30 seconds and tested yearly for a full 90 minute duration. Written records of testing are to be kept for examination by the authority having jurisdiction.

TROUBLE-SHOOTING

- The emergency lights do not operate -
 - If the charge indicator light is off: Check that the circuit breaker for AC supply is on.
 - If the charge indicator light is on:
 - Check that battery is properly connected.
 - If remote lights are connected to equipment turn off AC supply and disconnect remote circuit wires from equipment. Turn on AC supply and depress the test switch. If equipment mounted lights are now on, check remote circuit for short or over load condition and correct as required. Then reconnect circuit wires and restore AC power.
 - If problem persists, replace battery.
- Emergency lights are dim - battery not fully charged. Allow battery to recharge for 24 hours and then retest. If lights are still dim, replace battery.

WIRING DIAGRAM

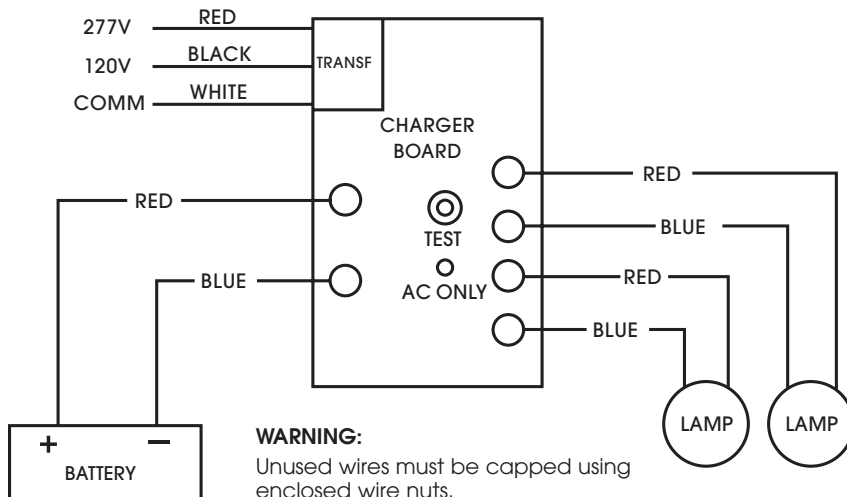

NOTE: LAMP HEAD INSTALLATION INSTRUCTION

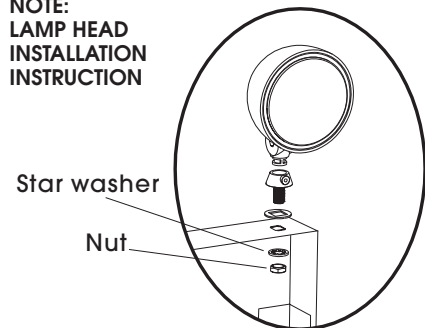

WARRANTY

Juno Lighting Group warrants that its products are free from defects in material and workmanship. Juno Lighting Group's obligation is expressly limited to repair or replacement, without charge, at Juno Lighting Group's factory after prior written return authorization has been granted. This warranty shall not apply to products which have been altered or repaired outside of Juno Lighting Group's factory. This warranty is in lieu of all other warranties, expressed or implied, and without limiting the generality of the foregoing phrase, excludes any implied warranty of merchantability. Also, there are no warranties which extend beyond the description of the product on the company's literature setting forth terms of sale.

Product Services Phone (888) 387-2212

1300 S. Wolf Rd • P.O. Box 5065 • Des Plaines, IL 60017-5065 • Phone: 800-323-5068 • www.junolightinggroup.com



JUNO Lighting Group